

BALASORE SCHOOL OF ENGINEERING

SUBJECT-STEEL DESIGN-II

SUBJECT CODE-CET 502(TH-02)

BRANCH-CIVIL

SEMESTER-5TH

ER.SHUCHISMITA ROUT

CHAPTER – 1

[2 Marks Ques]

Q. What do you mean by action in the limit state method of design ?

[2015(s), 1-a]

Ans: The primary cause for state of deformations in a structure such as dead, live, wind, seismic and temperature loads is commonly known as action in the limit state method of design.

Q. List two important advantages of welding over bolting ? [2016(s),2-a]

Ans: Welding is more adaptable than bolting because even circular sections can be easily connected by welding

Welded joints are more rigid and alternations in the connections can be easily made in the design.

Q. How are the structural members graded ?[2017(W)1(A)]

Ans: 3 types

- (1) Steel structures
- (2) R.C.C. structure
- (3) Timber structure

Q. State any two physical properties of structural steel ? [2017 (W)(New)1(a)]?

Ans-(a) Unit mass of steel , ... = 7850 kg/m³

b) Modulus of elasticity, E= 2.0 x 10⁶ N/mm²

c) Poisson's ratio, $\mu=0.3$

[5 Marks Ques]

Q. Explain the special considerations that are to be taken care of in excel design ? [2018(s) 5-b]

- Ans:**(i) Minimum thickness : The minimum thickness of the structural steel members are to be specified in view of corrosion, other use a very small amount of conversion may reavelt into reduction of large percentage of effective area.
- (ii) Shape and size :- Steel is manufactured in rolling mills and are available in standard shapes and sizes.
- (iii) Connection design:- During fabrication and assembling various standard sections in a member and the members them selves in a structure are to be suitably connected by welling , bolting, riveting and pins.
- (iv) Buckling:- As the strength to mass ratio of steel is very high, the permissible load per unit area is much higher steel compared to timber or concrete

Q. Write down the advantages and disadvantages of steet structures? [2018 (W) (New)2(B)] (2017 (w) New 1 (c)) [2019 (w)1(a)]

- * It has high strength per unit mass.
 - * It has assured quality and high durability.
 - * Speed of Construction is another important advantage of steel structure.
 - * Steel structures can be strengthened at any later time, if necessary.
It needs just welding additional sections.
 - * By using bolted corrections, steel structures can be easily dismantled and transported to other sites quickly.
 - * Meterial is reusable
- Disadvantage:-
1. It is susceptible to corrosion.
 2. Maintenance cost is high.

3. Steel members are costly.

CHAPTER:2

[2 Marks Ques]

Q. List two important advantages of welding over bolting? [2015(s), 2-a]

Ans:(i) Welding is more adaptable than bolting because even circular sections can be easily connected by welding.

(ii) It is quicker and speedier as there is no necessarily of making holes for fasteners.

Q. What is the angle between fusion faces for fillet weld ? [2017(s), 2-a]

Ans:The angle between fusion faces for fillet weld 60° to 120° ,

Q. Mention 2 advantages of weld joint? (2018(w)(new)4(B))

Ans:(i) Skilled labour and electricity are required for welding.

(ii) Internal stresses and warping are produced due to uneven heating and cooling.

Q. Define effective area of fillet weld ? [2016(W)1(C)]

Ans:Effective area of fillet weld = effective length \times throat thickness
throat thickness = 0.7

Q. Mention two disadvantages of weld joint ? (2017(W),3(A))

Ans:Disadvantages of weld joints are

(i) Skilled labour and electricity are required for welding

(ii) Internal stress and warping are produced due to uneven heating and cooling.

(iii) Welded joints are more brittle and therefore their fatigue strength is less than the member joined.

(iv) Defect like Internal air pockets slag inclusion and incomplete penetrate are difficult to detect

Q. What is the recommended throat thickness for incomplete penetration bolt welds welded from one side only ?

Ans:The penetration of the weld metal is generally incomplete and the effective throat thickness is taken as $(5/8) \times$ thickness of thinner part connected. The change in thickness while joining unequally thick plates should be gradual. A taper not exceeding 1 in 5 is provided when the difference in thickness of

parts exceeds 25 % of the thickness of the thinner part or 30 mm, whichever is greater.

Q. Write down the types of bolts which are commonly used? [2018 1(W) (new) 2(a)]

Ans:- (a) Unfinished (Black) Bolts.

b) Finished (Turned) Bolts

c) High strength Acition grip (HSFG) Bolts.

Q. Define efficiency of a joint ? [2018 (W) new, 2 (a)]

Ans:- Efficiency $n = \frac{\text{Strength of joint}}{\text{Strength fo solidplate}} \times 100$

[5 Marks Ques]

Q) Define the following terms with diagram:

- (i) Pitch:- It is the centre to centre spacing of the bolts in a raw, measured along the direction of load . It is denoted as 'P'.
- (ii) Gauge distance:- It is the distance between the two consecutive bolts of adjaunt rows and is measured at right angles to the direction of load.
- (iii) Edge distance:- It is the distance of centre of bolt hole from the adjacent edge of the plate.
- (iv) End distance:- It is the distance of the nearest bolt hole from the end of the plate.

Q. List the assumptions made in the design of bearing bolts along with their limitations. [2016(s), 1-b]

Ans: Assumptions:

- The stress distribution on the plates between the bolt holes is uniform
- The friction between the plates is negligible
- The shearing stress is uniformly distributed and the cross-section of the bolts.
- the bolts in a group share the direct load equally
- Bending stresses developed in the bolts is neglected.

Limitations:

- Assuming is not fully correct because actual stress distribution on the plates is not uniform in working conditions and initially the stress are very near the bolt holes due to stress concentration.
- Regarding Assumption: It is fact that friction exists between the plates to be connected as they are held against each other in snug tight bolts. Even if this assumption is not exactly true, but it leads to safer side in the design.
- Regarding assumption: Through the variation of shear stress over a circular cross section is parabolic, it could be averaged and taken to be uniform as equivalent stress.
- assumption is only justified not the ultimate stage, when all the bolts have to fail by redistribution of forces, otherwise fail bolts away from the C.G of the bolts groups experience more loads.
- Assumption is justified when eccentricity of the load is very small

Q. What is block shear failure ? Explain with sketches for the cases of bolted and welded connection ? [2016(s) 2-b]

Ans: The type of failure that along a parts involving tension on one plane and shear on a perpendicular plane is called block shear failure. When applied tensile load is increased the fracture strength of the weaker plane is approached. However, this plane does not fail as it is restrained by the stronger plane band the load can still be increased until the fracture strength of stronger plane is reached. By this time the weaker plane would have yields. Thus, at failure, the total strength equal fracture strength of stronger plane plus yield strength of weaken plane.

Block shear failure of bolted Joints.

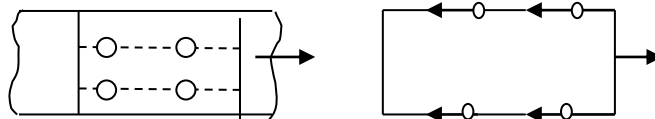

Block shear failure for plates

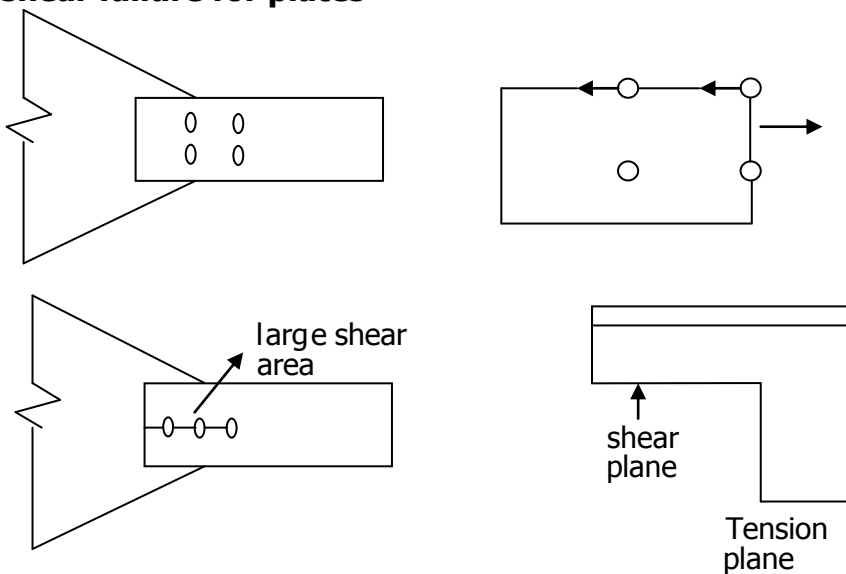

Block shear failure of welded Joints.

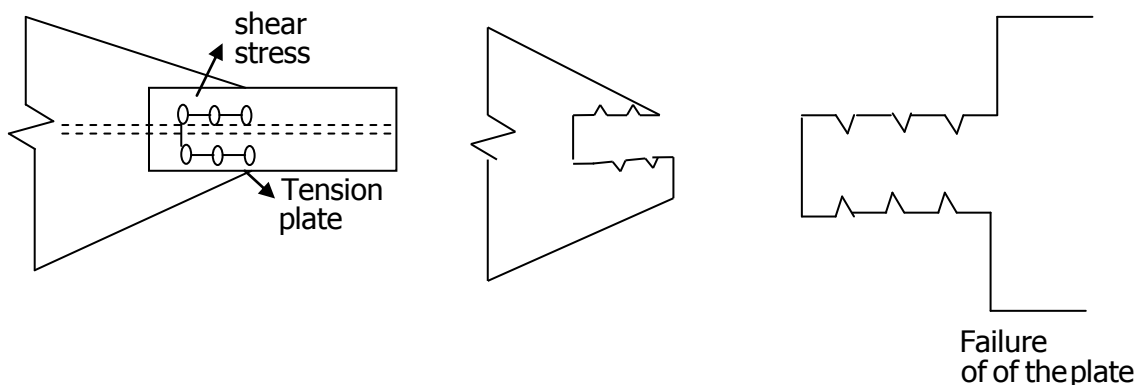

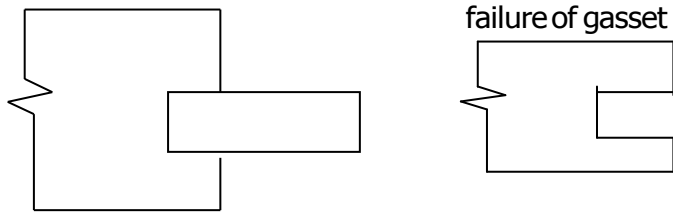

Q) Discuss the advantages and disadvantages of bolted connection? [2017 (w) new, 6(b)]

Ans:-Advantages;-

1. Making joints is noiseless.
2. Do not need skilled labour.
3. Needs less about.
4. Connections can be put to use immediately.
5. Accommodations minor discrepancies in dimensions.

Disadvantages:-

1. Tensile strength is reduced considerably due to stress concentrations and reduction of area at the root of the threads.
2. Rigidity of joints is reduced due to loose fit, resulting into excessive deflections.
3. Due to vibrations nuts are likely to loosen, endangering the safety of the structures.

Q. Write down the advantages of welded connections? [2018 (w) (new) 2 (b)]

Ans:-(1) Due to the absence of gusset plates, connecting angles etc, welded structures are lighter

- 2) The absence of making bores for fasteners makes welding process quicker.
- 3) Welding is more adaptable than bolting or riveting. For example, even circular tubes can be easily connected by welding.
- 4) It is possible to achieve 100% efficiency in the joint.
- 5) Noise produced in welding process is relatively less.
- 6) Welded connections have good aesthetic appearance.
- 7) Welded connection is airtight and watertight.

Q. Explain different types of bolt welds with sketch ? [2015(s), 1-b]

Form of weld sketch symbol

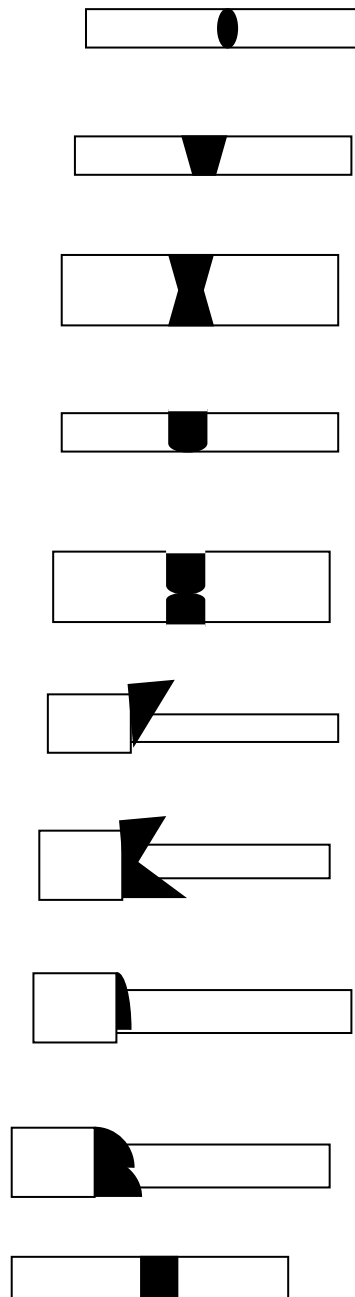

Q) Define the following terms: [2018 (w) (new) 7 (b)]

- (i) Column:- A column is a vertical member which effectively takes load by compression.
- (ii) Pier :- An intermediate support for the adjacent ends of two bridge spans.

- (iii) Buttress:- A structure of store or brick against a wall to strengthen or support it.
- (iv) Eccentricity load :- A load on a column or pile which is nonsymmetrical with respect to the central axis, therefore proceeding a Bending moment.
- (v) Non-load bearing wall:- A wall capable only of supporting its own weight and (if it is an exterior wall) capable of resisting the force of the wind blowing against it, it cannot support an imposed load.

[7Marks Ques]

Q. Find the maximum force that can be transmitted through a double bolted chain lap joint consisting of 6 bolts in 2 rows connecting two plates of thickness 12 mm and 10 mm. Given that M – 16 bolts of grade 4.6 and plates of Fe-410 are to be used? [2019(w)(new)1,c]

Ans: thickness of the plate $t_1 = 12$ mm and $t_2 = 10$ mm. total number bolts $n = 6$, diameter of the both $d = 16$ mm. Grade of bolt = 4.6, plate material = Fe-410, $f_y = 250$ MPa.

Minimum pitch $p = 2.5 d = 2.5 \times 16 = 40$ mm

Minimum edge distance to sheared/head flame out edge = 30 mm.

∴ Total plate width = $2 \times 40 + 2 \times 30 = 140$ mm

For M-16 bolts of grade 4.6

Diameter of bolt hole $d_n = 18$ mm

Ultimate strength $f_{ub} = 400$ MPa

Partial safety factor $\gamma_{mb} = 1.25$

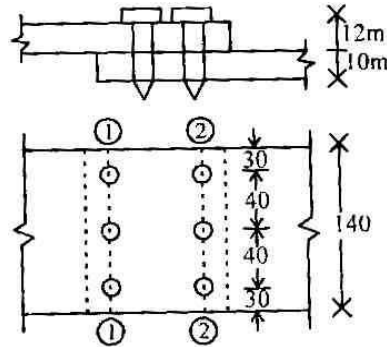

For FE-410 plate

Ultimate Stress $f_u = 410$ Mpa

Partial safety factor $\gamma_{m1} = 1.25$, $\gamma_{m0} = 1.1$

Strength of the plates in the joint done to rupture

Strength of the thinner plate will be minimum,

$$T = 10 \text{ mm}$$

Since there is no staggering, $p_{si} = 0$

Number of bolt holes in the critical section

$$2 - 2 , n = 3$$

Net effective area of the plate, $A_n = [b - ndn + 0]t$

$$= [140 - 3 \times 18 + 0] \times 10 = 860 \text{ mm}^2.$$

Design strength of the plate in the joint.

$$T_{dn} = \frac{0.9 A_n f_u}{\gamma_{m1}} = \frac{0.9 \times 860 \times 410}{1.25}$$

$$= 253872 \text{ N} = 253.87 \text{ kN}.$$

Strength of bolts in the joint :

Design strength in shear :

Bolts are in single shear and assuming that the threads intercept the shear plane in each bolt , $n_n = 1$ $n_s = 0$. Net shear area of the bolt at thread,

$$A_{nb} = 157 \text{ mm}^2 \left\{ \approx 0.78 \frac{7}{4} (d)^2 \right\}$$

Design strength in bearing :

The bearing of the bolt against the thinner plate will be critical

Nominal strength/bolt $V_{npb} = 2.5 K_b d t f_u$ Where

$$\left. \begin{array}{l} \text{(a)} \quad \frac{e}{3d_0} = \frac{30}{3 \times 18} = 0.56 \\ \text{(b)} \quad \frac{p}{3d_0} - 0.25 = \frac{40}{3 \times 18} - 0.25 = 0.491 \\ \text{(c)} \quad \frac{f_{ub}}{f_u} = \frac{400}{410} = 0.9756 \\ \text{(d)} \quad 1.0 \end{array} \right\} \text{least} = 0.491$$

$$\begin{aligned} V_{npb} &= 2.5 \times 0.491 \times 16 \times 10 \times 410 \\ &= 80524 \text{ N} = 80.52 \text{ kN / bolt} \end{aligned}$$

Since the length of the joint, as well as grip length are small and there is no passing plates, the reduction factors $\beta_{lj} = \beta_{lg} = \beta_{pk} = 1$

Nominal shear strength

$$\begin{aligned} V_{nsb} &= \frac{f_{ub}}{\sqrt{3}} (n_n A_{nb} + n_s A_{sb}) \\ &= \frac{400}{\sqrt{3}} (6 \times 157 + 0) = 217546 \text{ N} = 217.55 \text{ kN} \end{aligned}$$

Design strength in shear

$$V_{dsb} = \frac{V_{nsb}}{\gamma_{mb}} = \frac{217.55}{1.25} = 174.04 \text{ kN}$$

Design strength of bolts in the joint

$$V_{dpb} = \frac{V_{nsb}}{\gamma_{mb}} = \frac{80.52}{1.25} = 64.42 \text{ kN}$$

Design strength of bolts in the joint

$$\begin{aligned} V_{db} &= V_{dsb} \text{ or } V_{dpb} \text{ which is less} \\ &= 174.04 \text{ kN} \end{aligned}$$

Strength of the joint

$$\begin{aligned} &= \text{Minimum strength of the plate or strength of the bolts } T_{dn} \text{ or } V_{db} \text{ which is less} \\ &= 253.87 \text{ kN or } 174.04 \text{ kN which is less.} \\ &= 174.04 \text{ kN} = \text{maximum force transmitted.} \end{aligned}$$

Alternative solution : Since width of the plates are not given in the question, the strength of the joint per pitch width may be calculated and shown as the answer also.

Q. Design a single bolted double cover butt joint to connect boiler plate thickness 12mm for maximum efficiency. Use M16 bolts of grade 4.6. Boiler plates are $F_e 410$ grade. Find the efficiency of the joint.[2019(w)3]

$$D=16\text{mm}, d_o=18\text{mm}, f_{ub}=100 \text{ N/mm}^2$$

$$F_e = 410 \text{ N/mm}^2 \text{ if } t = 12\text{mm}$$

Since it is double cover butt joint, the bolts are in double shear one section at shank and another at root.

Nominal strength of a bolt in sheam.

$$\begin{aligned} &= \frac{400}{\sqrt{3}} \left(1 \times \frac{\pi}{4} \times 16^2 + 1 \times 0.78 \times \frac{\pi}{4} \times 16^2 \right) \\ &= 82651 \text{ N} \end{aligned}$$

$$\text{Design strength in sheam} = \frac{82651}{1.25} = 66121 \text{ N}$$

Assume bearing strength is more then it.

To get Max^m efficiency strength of plate per pitch width should be equated to strength of a bolt.

To avoid failure of cover plates, the total thickness of cover plates should be more then the thickness of main plates.

Provide cover plates of 8 mm thickmen.

Design strength of plate per pitch width,

$$\begin{aligned} &= \frac{0.9 \times 410 \times (P-18) \times 12}{1.25} \\ &= 3542.4(P-18) \end{aligned}$$

Equating (a) to (b) to get max^m efficiency we get, $3542.5(P-18) = 66121$

$$\therefore P = 36.67 \text{ mm}$$

$$\text{Minimum pitch} = 2.5 \times 16 = 40 \text{ mm}$$

$$\therefore \text{Provide bolts at } P = 40 \text{ mm}$$

Check for strength of bolts in bearing.

$$K_b \text{ is the min}^m \text{ of } \frac{e}{3d_o}, \frac{P}{3d_o}, -0.25, \frac{f_{ub}}{f_u}, 1.0$$

Assuming Sufficient 'e' will be provided

$$K_b = 0.4907$$

∴ Design Strength of bolt in bearing

$$= \frac{2.5 \times 0.4907 \times 16 \times 12 \times 400}{1.25}$$

$$= 75372N > 66121N$$

Hence, the assumption that bearing strength is more than design shear is correct.

Since pitch provided is slightly more than required from strength of plate is more than the strength of the bolt.

∴ Design strength joint per 40mm width=66121N

Design strength of solid plate per 40 mm width

$$= \frac{250 \times 40 \times 12}{1.1} = 109091N$$

∴ Max efficiency of joint = $\frac{66121}{109091} \times 100$

$$= 60.61\%$$

[CHAPTER : 3]

Q. How is the total tensile reinforcement in a two way reinforced rectangular footing distributed across the resisting section in short direction. [2012(s)]

Ans: For reinforcement in short direction a central band equal to the width of footing shall be marked along the length of footing and portion of the reinforcement determined on accordance with the equation given below should be uniformly distributed across the central band.

$$\frac{\text{Reinforcement in central band width}}{\text{Total reinforcement in short direction}} = \frac{2}{\beta + 1}$$

Where, β = the ratio of the long side to the short side of the footing.

Q. Under what condition a block shear failure is expected in tension member ?

Ans: The block shear failure occurs along a path involving tension on one plane and shear on a perpendicular plane.

Q. What will be the buckling class of ISHB 400 @ 907 N/m about z-z and y-y axis ?

Ans: The buckling class of ISHB 400 @ 907 N/m about z-z axis will be 18, 15 about y-y axis will be 3.01.

Q. Under what condition a block shear failure is expected in tension member ?

Ans: The block shear failure occurs along a path involving tension on one plane and shear on a perpendicular plane.

Q. Block Shear:- [2019(w), 7(b)]

Ans:-The block shear failure occurs along a path involving tension one plane and shear on a perpendicular plane. When applied tensile load is increased the fracture strength of the weaker plane is approached. However, this plane does not fail as it is restrained by the stronger plane. The load can still be increased until the fracture strength of the stronger plane is reached. During this time, the weaker plane is yielding. The total strength equals the fracture strength of the stronger plane plus the yield strength of weaker plane. At the connected end, failure of a tension member may occur along a path involving shear along one plane and tension on a perpendicular plane along the fastener. This type of failure is known as block shear failure.

$$T_{db} = \frac{A_{vg}f_y}{\sqrt{3}r_{no}} + \frac{0.9A_{tn}f_u}{r_{ne}}$$

$$T_{db} = \frac{0.9A_{vg}f_u}{\sqrt{3}r_{me}} + \frac{A_{tg}f_y}{r_{no}}$$

Q. Explain different modes of failure of tension member? [2019 (w) new, 2 (c)]

Ans⊗1) Design strength due to yielding of gross section:-

$$T_{dg} = \frac{A_g F_y}{r_{no}}$$

Where, f_y = Yield stress of the material.

A_g = Gross area of the cross-section.

r_{no} = Partial safety factor for failure in tension by yielding = 1.1

2. Design Strength due to rupture of critical section :-

$$T_{dn} = \frac{0.9 A_n f_u}{r_{me}}$$

$$A_n = \left[b - n d_o + \sum \frac{p_{si}^2}{4 g_i} \right] t$$

For threaded rods and bolts

$$T_{dn} = \frac{0.9 A_n f_u}{r_{xe}}$$

$$\text{Single angle:- } T_{dn} = \frac{0.9 A_{nc} f_u}{r_{me}} + \frac{\beta A_{go} f_y}{r_{mo}}$$

A_{nc} = net area of the connected leg

A_{go} = gross area of the outstanding leg.

$$B = 1.4 - 0.076 \left(\frac{w}{t} \right) \left(\frac{f_y}{f_u} \right) \left(\frac{b_s}{L_c} \right) \leq \frac{f_u r_{no}}{f_y m_e} \geq 0.7$$

Design strength due to shear Block :-

$$T_{db} = \frac{A_v g f_y}{\sqrt{3} r_{mo}} + \frac{0.9 A_t n f_u}{r_{me}}$$

$$T_{db} = \frac{0.9 A_v n f_u}{\sqrt{3} r_{me}} + \frac{A_t g f_y}{r_{mo}}$$

Q A tie member consists of 2 ISMC 250. The channels are connected on either side of a 12mm thick gusset Plate. Design the selded joint to develop the full strength of the tie. However the overlap is to be limited to 400mm? [2019(W), New 2 (b)]

Ans:- For ISMC 250, [From steel tables]

Thickness of web = 7.1mm

Thickness of Flange = 14.1 mm

Sectional area= 3867 mm²

$$\begin{aligned} \text{Tensile design strength of each channel} &= \frac{A_g F_y}{1.1} \\ &= \frac{3867 \times 250}{1.1} \\ &= 878864 \text{N} \end{aligned}$$

Weld thickness

Min thickness = 3 mm

Max thickness = 7.1 - 1.5 = 5.6mm

Provide S=4mm weld

∴ Throat thickness, t=0.7×4=2.8mm

$$\begin{aligned} \text{Strength of weld} &= L_w t \frac{f_u}{\sqrt{3}} \frac{1}{r_{nw}} \\ &= L_w \times 2.8 \times \frac{410}{\sqrt{3}} \times \frac{1}{1.25} \end{aligned}$$

Equatin strength of weld to tensile strength of the we get.

$$L_w \times 2.8 \times \frac{410}{\sqrt{3}} \times \frac{1}{1.25} = 878804$$

$$\therefore L_w = 1658 \text{mm}$$

Since allowable length to 400 +400mm it needs lot weld. The arrangement can be as shown in the fig. With two slots of length 'x' ,

Then

$$400 + 400 + (250 - 2 \times 30) + 4x = 1658$$

$$= x = 167 \text{mm}$$

(as 2s length of weld will be in effective at each term)

Provide $x=185\text{mm}$ as shown fig.

Q. A tension member consists of a flat $100\text{ mm} \times 8\text{ mm}$ which is connected to a gusset plate of 10 mm thick by 2 nos of 16 mm dia bolts as shown in fig below. Determine the strength of the flat against yielding, rupture and block shear. Also determine the maximum load the joint can carry safely. Assume steel of grade Fe410 and heating bolts of property class 4.6 in the field. [2015(w),5.c]

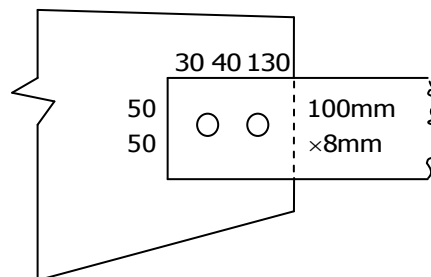

Ans:For Fe 410 grade of steel $f_u = 410\text{ Mpa}$, $f_y = 250\text{ Mpa}$

Partial safety factor

$$\gamma_{mo} = 1.1, \gamma_{mb} = 1.25$$

Tensile strength rule to gross section yielding

$$T_{ds} = \frac{A_g f_y}{\gamma_{mo}} = \frac{2058 \times 250}{1.1} \times 10^{-3} = 467.7\text{ kN}$$

Tensile strength due to net section rupture

Length of out standing leg $w = 100$

Shear leg width $b_s = w = 100\text{ mm}$

Weld length along the direction load

$$L_c = 2 \times 100 + 150 = 350\text{ mm}$$

$$\beta = 1.4 - 0.076 \left(\frac{w}{t} \right) \left(\frac{f_g}{f_y} \right) \left(\frac{bs}{Lc} \right) \leq \left(\frac{f_u}{f_y} \right) \times \frac{\gamma_{mo}}{\gamma_{mb}} \geq 0.7$$

$$= 1.4 - 0.076 \times \frac{160}{8} \times \frac{250}{410} = 0.85 \geq 0.7$$

$$\text{Also, } \frac{f_u}{f_y} \times \frac{\gamma_{mo}}{\gamma_{mb}} = \frac{410}{250} \times \frac{1.1}{1.25} = 1.44$$

hence, $\beta = 0.85$

Net area of connected leg

$$A_{nc} = \left(100 - \frac{8}{2} \right) \times 8 = 768 \text{ mm}^2$$

Gross area of connected leg

$$A_{go} = \left(100 - \frac{8}{2} \right) \times 8 = 768 \text{ mm}^2$$

$$T_{dn} = \frac{0.9 A_{nc} f_u}{r_{mb}} + 0.85 \frac{A_{go} f_y}{r_{mo}} = 0.9 \left[\frac{768 \times 410}{1.25} \right] + 0.85 \left[\frac{768 + 250}{1.1} \right]$$

$$= 369.763 \text{ kN} \times 10^{-3}$$

CHAPTER : 4

[2 Marks Ques]

Q. Name different compression members on the basis of their place of use? [2017(w),1(a)]

Ans: Different compression members on the basis of their place of use are as follows
strut, column, boom rafter etc.

Q. What is slenderness ratio? [2018(w),new,3(a)],[2019(w),1(e)]

Ans: Slenderness ratio is the ratio of effective length of compression member to the approximate radius of gyration of member.

It is denoted by λ

$\lambda = l/r$, where l = effective length of compression

R = radius of gyration of member

[5 Marks Ques]

Q. Enumerate the step in design of compression member ?

Ans:Step :1 The slenderness ratio for the compression member and value of yield stress for the steel are assumed

Slenderness ratio

Rolled section	70 to 90
For strut	110 to 130
Compression member	
Arrying large load	40

Step 2: The effective sectional area (A) required for compression member is determined, $A (P/6_{ac})$

Wher p = Load to be carried by the member

Step:3 From steel section tables, section for the compression member of the required area is selected.

Step:4:- Knowing the geometrical properties of the section, slenderness ratio is emputed and allowable axial stress in compression is foud from 15 : 800 – 1984 for the quality of steel assement.

Step: 5:- The safe load carrying capacity of the compression member is determined

Q. Design a steel column using channel section only to carry a factored axial load of 350 kN. The column is 3.5 m long and is effectively held in position and restrained against rotation at both the ends. Take $f_y = 250$ MPa and assume wind/earthquake actions.[2016(w),7.c].

Ans: $P_u = 350$ kN, $L = 3.5$ m (both end fixed), $f_y = 250$ MPa, WL/EL = actions

Assuming permissible design compressive stress 80 MPa.

$$A_{\text{reqd}} = \frac{350 \times 10^3}{80} = 4375 \text{ mm}^2$$

Let us try ISMC 300 @ 351.2 N/m having area

$$A = 4564 \text{ mm}^2$$

$$\gamma_{\text{min}} = \gamma_{yy} = 26.1 \text{ mm},$$

$$\therefore \gamma_{\text{min}} = \gamma_{yy} = 26.1 \text{ mm}$$

For effectively held in position and restrained against rotation at both the ends,

$$KL = 0.65 L = 0.65 \times 3500 = 2275 \text{ mm}$$

Maximum slenderness ratio

$$\lambda_{\text{max}} = \frac{KL}{\gamma_{\text{min}}} = \frac{2275}{26.1} = 87.16 < 250$$

for – channel section, the buckling class is 'e'.

$$\text{for } \frac{KL}{r} = 87.16 \text{ and } f_y = 250 \text{ MPa}$$

Permissible compressive stress, by interpolation, from table 9 (c)

$$f_d = 121 + \frac{136 - 121}{20 - 80} (90 - 87.16) = 125.26 \text{ MPa}$$

$$\begin{aligned} \text{Design strength } P_d &= A f_{ed} = 4564 \times 125.26 \\ &= 571687 \text{ N} = 571.69 \text{ kN} > 350 \text{ kN} \Rightarrow \text{safe} \end{aligned}$$

Check for limiting thickness:

$$\epsilon = \sqrt{\frac{250}{f_y}} = \sqrt{\frac{250}{250}} = 1$$

From steel table, $h = 300$ mm, $b_f = 90$ mm, $t_f = 13.6$ mm, $t_w = 7.6$ mm, $R_1 = 13.0$ mm.

$$\text{Here } b = 100 \text{ mm, } d = h - 2(t_f + R_1)$$

$$= 300 - 2 (13.6 + 13.0) = 246.8 \text{ mm}$$

For channel section

$$\left. \begin{aligned} \frac{b}{t_f} &= \frac{100}{13.6} = 7.35 < 15.7E = 15.7 \times 1 = 15.7 \\ \frac{b}{t_w} &= \frac{246.8}{7.6} = 32.47 < 42E = 42 \times 1 = 42 \end{aligned} \right\} \text{Table - 2}$$

Q. Determine the axial load capacity of the column ISHB300@577 N/m if the length of column is 3m and it's both end pinned? [2019 (w) 2(d)]

And:- for rolled steel sections

$$F_y = 250 \text{ N/mm}^2, F_u = 410 \text{ N/mm}^2 \text{ and } E = 2 \times 10^5 \text{ N/mm}^2$$

For both end pinned columns,

$$KL = L = 3\text{m}$$

For ISHB 300 @ 577 N/M

$$h = 300\text{mm}, b_f = 250\text{mm}, t_f = 10.6\text{mm}, A_e = A = 74\text{B}4\text{mm}^2$$

$$\therefore \frac{h}{b_f} = 1.2 \text{ and } t_f < 40\text{mm}$$

Hence according to table - 10 in Is-800

It fails under buckling class 'b' for buckling about Z-z axis and under class 'i' for buckling about y-y axis. From steel table

$$R_{\min} = r_{yy} = 54.1\text{mm}$$

$$\therefore f_{cc} = \frac{\pi^2 E}{\left(\frac{KL}{r}\right)^2} = \frac{\pi^2 \times 2 \times 10^5}{\left(\frac{KL}{r}\right)^2} = \frac{\pi^2 \times 2 \times 10^5}{\left(\frac{300}{54.1}\right)^2} = 641.92 \text{ N/mm}^2$$

Non-dimension alised effective slenderness ratio

$$\lambda = \sqrt{\frac{f_y}{f_{cc}}} = \sqrt{\frac{250}{641.92}} = 0.624$$

For bucking class b,

$$\therefore \phi = 0.5 [1 + \alpha(\lambda - 0.2) + \lambda^2]$$

$$\begin{aligned} \alpha = 0.34 &= 0.5 [1 + 0.34(0.624 - 0.2) + 0.624^2] \\ &= 0.767 \end{aligned}$$

$$\begin{aligned} \therefore f_{cd} &= \frac{f_y / r_{no}}{\phi + (\phi^2 - \lambda^2)^{0.5}} \\ &= \frac{250 / 1.1}{0.767} + (0.767^2 - 0.624^2)^{0.5} \\ &= 187.36 \text{ N/mm}^2 \end{aligned}$$

∴ Strength of column,

$$\begin{aligned}P_d &= A_c F_{cd} \\&= 7484 \times 187.36 \\&= 1402237 N \\&= 1402.237 KN\end{aligned}$$

$$\therefore \text{Working load} = \frac{1402.237}{1.5} = 934.823 kn$$

CHAPTER:5

[2 Marks Ques]

Q. What do you provide cleat angle in column base? [2015(w),1d]

Ans: The column is directly connected to the plate through cleat angles. The load is transferred to the base through bearing and cleat angle.

Q. Distinguish between slab base and gusseted base for steel columns? [2016(w),3.c]

Ans:Slab base: When the column is subjected to only direct loads the base can be designed by assuming a uniform bearing pressure from below for small loads a steel plate alone, shop welded to the column can be used to transmit the loads to the concrete pedestal such base plate is called slab base.

Gusset base : when the load on the column section is too large or when the axial load is accompanied by bending moments, usually a gusset base is provided. It consists of a base plate, two gusset plates and two gusset angles when bolted connections are made. In case welded connections are used gusset angles will not be required.

Q. Write design for axially loaded steel columns? [2016(s) 1-e]

Ans: Avg axial stress $\sigma_{ac} = P/A \Rightarrow P = \sigma_{ac} \times A$

P_a = allowable load

A = cross – sectional area of the column.

[5 Marks Ques]

Q. Design a suitable slab base for a column section ISHB 200 @ 365.9 N/m supporting an axial load of 400 kN. The base plate is to rest on a concrete pedestral of M20 grade? [2018(w),4.c]

Ans:Data given.

Column section = ISHB 200 @ 365.9 N/m

Axial load = 400 kN

Assume, allowable pressure intensity (σ_c) = 4N/mm²

Bending stress (σ_s) = 18 N/mm²

Step : 1 Load = 400 kN

$$A_{req} = (400 \times 10^3)/4 = 100000 \text{ mm}^2$$

$$L_B = 350 \text{ mm} , \quad B_B = 300 \text{ mm}$$

$$A_{pro} = 350 \times 300 = 105000 \text{ mm}^2$$

Step : 2 Upward pressure = $\frac{\text{Load}}{A_{pro}} = \frac{400 \times 10^3}{350 \times 300} = 3.8 \text{ N/mm}^2 < \sigma_c$

Step:3 Thickness of base plate

$$T_a = \sqrt{\frac{3w}{\sigma_s} \times \frac{a^2 - b^2}{4}}$$

A = greater projection beyond the column face

$$= \frac{L_B - D_f}{2} = \frac{350 - 200}{2} = 75 \text{ mm}$$

B = smaller projection beyond the column face

$$= \frac{B_B - D_f}{2} = \frac{300 - 200}{2} = 50 \text{ mm}$$

$$T_B = \sqrt{\frac{3 \times 3.8}{185} \times \left(75^2 - \frac{50^2}{4}\right)} = 17.55 \text{ mm} \square 40 \text{ mm}$$

Size of the base plate = 350 mm × 300 mm

Thickness of the base plate = 40 mm

Use 150 × 150 × 8 mm cleat angle.

Q. Web crippling and web buckling ? [2019 (w), 7(a)]

Ans: - Web Crippling :- Near the support web of the beam may cripple due to lack of bearing capacity. The crippling occurs at the root of the radius.

Web buckling:- Certain portion of beam at support acts as column to transfer the load from beam to the support. Hence under this compressive force the web may buckle. This may happen under a counteracted load on the beam also. The load dispersion angle may be taken as is.

Q. Design a slab base for a column ISHB 300 @ 577 carrying an axial load of 1000KN. M 20 concrete is used for the foundation. Provide welded connection between column and base plate [2019 (W) 2 (e)]

Ans:- Bearing strength of concrete

$$\begin{aligned} &= 0.45 f_{ck} \\ &= 0.45 \times 20 \\ &= 9 \text{ N/mm}^2 \end{aligned}$$

Factored load $F_u = 1000 \text{ Kn}$

$$\begin{aligned} \therefore \text{Area of base plate required} &= \frac{1000 \times 10^3}{9} \\ &= 111111 \text{ mm}^2 \end{aligned}$$

Provide 360 x 310 size Plate

$$\text{Area Provided} = 360 \times 310 = 111600 \text{ mm}^2$$

$$\text{Pressure} = \frac{1000 \times 10^3}{111600} = 8.96 \text{ N/mm}^2$$

$$\text{Projections are } a = \frac{360 - 300}{2} = 30 \text{ mm}$$

$$b = \frac{310 - 250}{2} = 30 \text{ mm}$$

$$\begin{aligned} \therefore t_s &= \left[\frac{2.5 \times 8.96 \times (30^2 - 0.3 \times 30^2) \times 1.1}{250} \right]^{0.5} \\ &= 7.88 \text{ mm} \end{aligned}$$

Thickness of flange of IsHB300 @ 577 N/m is 10.6mm

Provide 12mm thick plate.

Connecting 360x310x12m Plate to concrete foundations Use 4 bolts of 20mm diameter 300mm long to another the plate

Total length available for welding

$$= 2 \times [250 + 250 - 7.6 + 300 - 2 \times 10.6]$$

$$= 1542.4 \text{ mm}$$

$$\text{Strength of weld} = \frac{410}{\sqrt{3}} \times \frac{1}{1.25} = 189.37 \text{ N/mm}^2$$

Let 'S' be the size of weld. The effective area of weld = 0.7 S Le

Where Le = effective length

∴ The design condition is $0.7 S L L_e \times 189.37 = 1000 \times 10^3$

$$= S L_e = 7543.8$$

Using 6 mm weld, $L_e = 1257 \text{ mm}$

After deducting for end return of the weld at the rate of twice the size of the weld at each end

Available effective length

$$= 1542.4 - 2 \times 6 \times \text{No. of returns}$$

$$= 1542.4 - 2 \times 6 \times 12$$

$$= 1398.4 > 1257 \text{ mm}$$

Hence 6mm weld is adequate

[7 Marks Ques]

Q. Design a slab base for a column ISHB 450 @ 855.4 N/m to carry an axial factored load of 900 kN. M30 concrete is used for the foundation. Provide welded connection between column and base plate.

[2018(w),6.c]

Ans: Assume steel of grade Fe 410

For Fe 410 mpa, $F_y = 250$ mPa

For M₃₀ grade of concrete

Bearing strength of concrete = $0.45 f_{ck}$

$$= 0.45 \times 30 = 13.5 \text{ N/mm}^2$$

Partial safety factor $\gamma_{mo} = 1.1$

$$\gamma_{mw} = 1.25$$

Properties of ISHB 450 @ 855.4 N/m

Thickness of flange, $t_f = 13.7$ mm,

Thickness of web, $t_w = 9.8$ mm

Depth of section, $D = 450$ mm,

Width of flange, $b_f = 250$ mm

$$\text{Required area of slab base, } A = \frac{1500 \times 10^3}{13.5}$$

$$= 111111.1 \text{ mm}^2 = 0.111 \text{ m}^2$$

Let us provide a square base plate

$$\text{Side of base plat} = L = B = \sqrt{0.111}$$

$$= 0.333 \text{ m} \approx 420 \text{ mm}$$

Provide a base plate 420×420 mm in size.

The bearing pressure of concrete.

$$w = \frac{P}{A_1} = \frac{1500 \times 10^3}{420 \times 420} = 8.50 \text{ N/mm}^2 < 13.5 \text{ N/mm}^2$$

Which is all right

$$\text{The greater projection } a = \frac{420 - 250}{2} = 85 \text{ mm}$$

$$\text{The smaler projection, } b = \frac{450 - 420}{2} = 15 \text{ mm}$$

Thickness of slab base,

$$t_s = \sqrt{2.5w(a^2 - 0.3b^2) \frac{\gamma_{mo}}{f_y}} = \sqrt{2.5 \times 8.50 \times 715.5 \times \frac{1.10}{250}}$$

$$= 25.86 = 28 \text{ mm} < 13.7 \text{ mm}$$

$$L_a = 2 \times 250 + 2 \times (250 - 9.8) + 2 \times (450 - 2 \times 13.7)$$

$$= 500 + 480.4 + 845.2 = 1825.6 \text{ mm}$$

Number of total end returns = 12

Effective length that can be provided

$$= 1825.6 - 12(2 \times 8) = 1633.6 \text{ mm}$$

Size of weld = 8 mm

Throat thickness, $t_1 = 0.78 \times 8 = 56 \text{ mm}$

Strength of weld/mm length.

Q. Determine the plastic section modulus of a T section having flange width 150 mm, flange thickness 16 mm, depth of web 150 mm and width of web 12 mm. [2018(w)new,4(b)].

Ans: Total area 'A' = $150 \times 16 + 150 \times 12$

$$= 4200 \text{ mm}^2 \text{ and } A/2 = 2100 \text{ mm}^2$$

$$\text{Flange area} = 150 \times 16 = 2400 \text{ mm}^2$$

Hence the neutral axis lies inside the flange and let it be at a distance y from the top of the flange.

$$\therefore 150 \times y = 2100 \text{ or } y = 14 \text{ mm}$$

$$\therefore Z_p = A_c Z_c + A_t \cdot Z_t$$

$$= 150 \times 14 \times 7 + 150 \times 2 \times 1 + 150 \times 1$$

$$= 14700 + 300 + 138600 = 153600 \text{ mm}^3$$

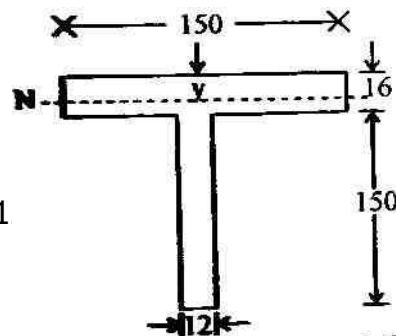

Q. Design a simply supported beam of span 1.5 m carrying a concentrated load of 300 kN at mid span. Width of support is 200 mm. Consider $f_y = 250 \text{ N/mm}^2$? [2019(w)5].

Ans: For F_e 410 grade of steel, $f_y = 250 \text{ MPa}$.

Maximum bending moment

$$M_s = \frac{wl}{4} = \frac{300 \times 1.5}{4} = 112.5 \text{ kNm}$$

Maximum shear force

$$= V_s = \frac{wl}{2} = \frac{300 \times 1.5}{2} = 225 \text{ kN}$$

$$\text{Required modulus of section, } Z_{cc.t} = \frac{M_s}{f_{abc.t}}$$

$$= \frac{112.5 \times 10^6}{250} = 681818 \text{ mm}^3 \quad 29$$

Let us try ISLB 200 2 199.2 N/m.

The relevant properties of the section are

Depth of section, $h = 200$ mm

Width of flange, $b_f = 100$ mm

Thickness of flange, $t_f = 7.3$ mm

Thickness of web, $t_w = 5.4$ mm

Moment of inertia, $I_z = 1696.6 \times 10^4$

Section modulus, $Z_{ez} = 169.7 \times 10^3$ mm³

Radius of web $d = h - 2(t_f + R_1)$

$$= 200 - 2 \times (7.3 + 9.5) = 166.4 \text{ mm}$$

Check for section classification

$$\varepsilon = \frac{\sqrt{250}}{f_y} = \sqrt{\frac{250}{250}} = 1.0$$

$$\text{outs tan t of flange, } b = \frac{b_f}{2} = \frac{100}{2} = 50 \text{ mm}$$

$$\frac{b}{t_f} = \frac{50}{7.3} = 6.849 < 9.4$$

$$\frac{d}{t_w} = \frac{166.45}{5.4} = 30.81 < 84$$

Hence, the section is plastic.

The permissible bending stress, $f_{abc,t} = 0.66 f_y$

And permissible shear stress, $Z_{ab} = 0.4 f_y$

Check for bending

$$f_{bc,t} = \frac{M_s}{Z_{ec}} = \frac{112.5 \times 10^6}{169.7 \times 10^3} = 662.9 / \text{mm}^2$$

which is safe

Check for shear

$$t_b = \frac{V_s}{A_v} = \frac{225 \times 10^3}{200 \times 5.4} = 208.33 \text{ N / mm}^2$$

which is right

Check for deflection

$$\delta_{\text{allowable}} = \frac{S_{pm}}{300} = \frac{1.5 \times 10^3}{300} = 7 \text{ mm}$$

$$\delta_{\text{cal}} = \frac{1}{48} \frac{wl^3}{EI} = \frac{1}{48} \times \frac{300 \times 10^3 \times (1.5 \times 10^3)^3}{2 \times 10^5 \times 1696.6 \times 10^4}$$

$$= 6.21 < 7 \text{ mm}$$

which is all right

CHAPTER :7

[2 Marks Ques]

Q. State the advantages of tubular sections?[2018(s)1-h]

Ans:The round tubular sections have as much as 30 to 40 percent less surface area than that of an equivalent rolled steel shape . Therefore, the cost of maintenance, cost of painting, fire proofing and/or other protective coating reduce considerably. The moisture and dirt do not collect on the smooth external surface of the tubes. Therefore the possibility of corrosion also reduces. The end of tubes are sealed. As a result of this, the interior surfaces are not subjected to corrosion. The interior surfaces do not need any protective treatment. The tubular section have moment resistance.

Q. Why tubular steel section preferred as compression member in place of rolled steel section ? [2016(s) 1-f]

Ans:The round tubular section have as much as 40 % less area than that of an equivalent rolled section. Therefore the cost of maintenance, cost of painting, fire proofing and other protective coatings reduce considerably.

Q. Name different compression members on the basis of their place of use? [2017(w),3.a]

Ans:(i) Strut
(ii) columns
(iii) boom
(iv) rafters.

CHAPTER:8

[2 Marks Ques]

Q. Define and state the significance of slenderness ratio ? [2017(s)2,a]

Ans: Slenderness ratio is the ratio of effective length of compression member to the approximate radius of gyration of member. It is denoted by λ .

$$\lambda = \ell/r$$

Where ℓ = effective length of compression member

R = radius of gyration of member.

Q. What do you mean by grading of timber ? [2017(s),5-a]

Ans: Timber are divided in grades by there permissible stress value. These are three types grade – I , grade – II, grade – III.

Q. What do you mean by grading of timber ? 2018(s) 6-a]

Ans: the method of designating the quality of a piece of timber is known as grading of timber, while grading the timber, the defects in timber are taken into consideration with respect to their size, number and location. Also the effect of density and slope of grains are taken density and slope of grains are tken into account while grading the timber.

Q. Differentiate between an isolated foating and a strip footing?

[2018(w),5.a]

Ans: An individual footing under a single column is known as an isolated footing. Where good soil and sufficient area is available, there footings are economical. If a number of footings in a lines are to be combined a strip footing is used. Differential settlement can be minimized by using such footing

[5 Marks Ques]

Q. Find the safe axias load on a circular sal column of diameter 15 cm and length of 3.5 m ?[2018(s),new,5(c)]

Ans:Effective length of column $L = 3500$ mm

Dia. of column (d) = 150 mm

Maximum slenderness ratio = $L/s = 3500/150 = 22.33 > 11$

For sal wood, safe working stress in axial compression parallel to the grown = 11.2 N/mm^2

And $\epsilon = 10300 \text{ N/mm}^2$

$$K_s = 0.582 \left[\frac{E}{f_{cb}} \right]^{1/2} = 0.582 \left[\frac{E}{f_{cb}} \right]^{1/2} = 0.582 \left[\frac{10,800}{11.2} \right]^{1/2} = 18.07$$

The slenderness ratio of the column is greater than K_s

The column is treated as a long column

\therefore permissible stress on the column.

$$F_c = \frac{0.329 E}{(L/d)^2} = \frac{0.329 \times 10,800}{(23.33)^2} = 6.52 \text{ N/mm}^2$$

safe axial load on the column.

$$P = \frac{6.52 \times \frac{\pi}{4} (150)^2}{1000} = 115.21 \text{ kN}$$

[7 Marks Ques]

Q. A sal wood (M.P.) column is 150 mm × 200 mm in cross section. Determine the safe axial load on the column if the unsupported length of the column is (i) 1.5 m (ii) 2.8 m (iii) 4.0 m Assume inside location and standard grade (Grade-I)?[2015(s),1-c]

Ans: Unsupported length of the column = 1.5

$$d = 150 \text{ mm}$$

$$\frac{s}{d} = \frac{1500}{150} = 10$$

$$k = 0.720 \sqrt{\frac{E}{f_c}}$$

$$E = 12.7 \times 10^3 \text{ M / mm}^2 \text{ (for sal wood)}$$

$$f_c = 7.4 \text{ N / mm}^2$$

$$k = 0.720 \sqrt{\frac{12.7 \times 10^3}{9.4}} = 25.8$$

$$\frac{s}{d} = k$$

So, it is a long column

$$\text{safe stress} = \frac{0.329 E}{(s.d)^2} = \frac{0.329 \times 12.7 \times 10^3}{(10)^2} = 42.44$$

$$\begin{aligned} \text{safe load carrying capacity} &= \text{safe stress} \times \text{area} \\ &= 42.44 \times 150 \times 200 \\ &= 1274.2 \text{ kN} \end{aligned}$$

(i) Unsupported length = 2.8 m

$$d = 150 \text{ mm}$$

$$s / d = \frac{2800}{150} = 18.66$$

$$k = 25.8 \quad S / D < K$$

So, it is long column

$$\text{safe stress} = \frac{0.329 E}{(s / d)^2} = \frac{0.329 \times 12.7 \times 10^3}{(18.66)^2} = 11.99612$$

$$\begin{aligned} \text{Safe load carrying capacity} &= \text{safe stress} \times \text{area} \\ &= 12 \times 150 \times 200 = 360 \text{ kN} \end{aligned}$$

(ii) Unsupported length column = 4 m

$$d = 150 \text{ mm} \quad s/d = 1500/150 = 26.66, \quad k = 25.8$$

$$s/d > k$$

so this is short column.

$$\text{safe stress} = \frac{0.329 E}{(s / d)^2} = \frac{0.329 \times 12.7 \times 10^3}{(26.66)^2} = 5.82$$

safe load carrying capacity = safe stress \times area

$$= 5.82 \times 150 \times 200$$

$$= 174.75 \text{ kN.}$$

CHAPTER:9

[2 Marks Ques]

Q. Where the critical section for computing maximum bending moment in each of the following coases lie: [2016(w) 1-j]

Ans:(a) Footing supporting a column.
(b) Footing supporting a massonary wall.

Q. Difference between an isolated footing and a strip footing [2018(w) 1-g]

Ans:An individual footing under a single column is known as an isolated footing. Where good soil and sufficient area is available, these footings are economical.

Q. If a no. of footings in a line are to be combined, a strip footing is used. Differential settlement can be minimized by uysing such footings. [2016(w),2.a]

Ans: In case of footing supporting a column at the face of the column, the critical section for computing maximum BM>
In case of footing supporting a masonry wall the critical section for computing maximum BM in the half between the centre line and the edge if the wall.

Q. What is the minimum value of the thickness of slopped footing at the edge when the footing rests on normal soil ? [2015(s) 1-h]

Ans:In reinforced and plain concrete footings, the thickness at the edge shall not be less than 150 mm for footings on soils. Nor less than 300 mm above the tops pf piles for footing on piles.

[7 Marks Ques]

Q. Find the design bending moment and shear force of an RCC footing for a masonry wall of 300 mm thick subjected to an imposed load of 50 kN/m on the footing including self weight of masonry walls.

[2018(w),5.c]

Ans: Assuming M20 concrete and Fe415 steel

$$\text{SBC of soil} = 120 \text{ kN/m}^2$$

Design constants.

$$R_c = 0.259, J_c = 0.904 \text{ and } Q_c = 0.914$$

$$\text{Width of footing } B = 50/120 = 0.41 \text{ m} \approx 0.45 \text{ m}$$

$$\text{Net upward pressure } P_0 = 50/0.45 = 111.11 \text{ kN/m}^2$$

Design of section

Maximum B.M occurs at section x-x distance $b/4$ from the centre of wall and its magnitude is given by

$$\begin{aligned} M &= \frac{P_0}{8} = (B - b) \left(B - \frac{b}{4} \right) \times 10^6 \text{ Nmm} \\ &= \frac{111.11}{8} (0.45 - 0.3) \left(0.45 - \frac{0.3}{4} \right) \times 10^6 \\ &= 0.78 \times 10^6 \text{ Nmm} \end{aligned}$$

$$d = \sqrt{\frac{Mu}{bQ_c}} = \sqrt{\frac{0.78 \times 10^6}{1000 \times 0.914}} = 29.23 \text{ mm}$$

Provides to total depth of 160 mm and a cover to the centre of the steel equal to 60 mm. so that available $d = 160 - 60 = 100 \text{ mm}$.

Check for shear :

For balanced section

$P = 0.44 \%$ for M 20 concrete and Fe415 steel

$$\mu_c = 0.28 \text{ N/mm}^2$$

$$K = 1.30$$

$$\text{Hence permissible shear stress} = K \mu_c = 1.30 \times 0.28 = 0.364$$

The critical section lies at a distance of $d = 100 \text{ mm}$

From the face of the wall hence distance of critical section from edge footing

$$= 1/2 (B - b) - d = 1/2 (0.45 - 0.3) - 0.1 = 0.025 \text{ m}$$

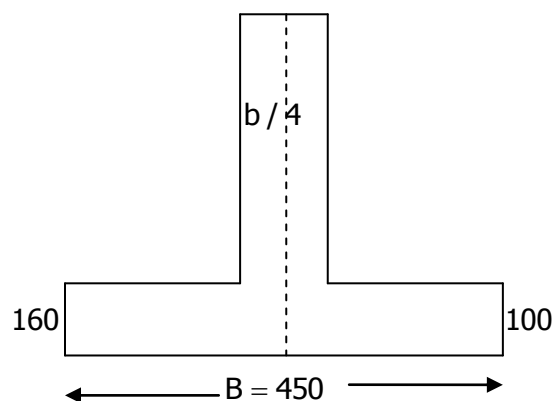

$$v = 50000 \times 0.225 = 11250 \text{ N/m}$$

$$\mu_v = \frac{v}{bd} = \frac{1250}{100 \times 100} = 0.1125 \text{ N/mm}^2$$

This is less than the permissible shear stress hence safe ($\mu_v < \mu_c$)

Design of reinforcement :

$$A_{st} = \frac{M}{\sigma_s + jd} = \frac{0.78 \times 10^6}{230 + 0.0904 \times 100} = 363.6 \text{ N/mm}^2$$

Using 12 mm Q bars

$$A = \pi/4 (12)^2 = 112 \text{ mm}^2$$

$$\text{spacing } S = \frac{1000 \times A}{A_s} = \frac{1000 \times 113}{364} = 310 \text{ mm}$$

Provide 12 mm ϕ bars @300 mm c / c

Area of longitudinal reinforcement

= 0.12 % area of cross section

$$= \frac{0.12}{100} \times 100 \times 160 = 192 \text{ mm}^2$$

$$\text{Spacing} = 1000 \times \frac{50.26}{192} = 201 \text{ mm}$$

Provide 8 mm ϕ bars @ 250 c / c.

Q. Design a square footing for a RCC column of 350 mm × 350 mm carrying a load of 500 kN. The SBC of the soil is 120 KN/m². The materials are grade M20 concrete and HYSD reinforcement of grade Fe415 for both the column and the footing?[2016(w),4.c]

Ans:Data given

Column size = 350 mm × 350 mm

Load = 500 kN

S.B.C. of soil = 120 KN/m²

F_{ck} = 20 N/mm²

F_y = 415 N/mm²

Step : 1 Column load = 500 kN

Total load = column load + foundation load

= 500 + (10 % of the column load)

= 500 + 50 = 550 kN

Ultimate load = 1.5 × 550 = 825 kN

Step -2 : A_q = ultimate load/S.B.C. = 825/120 = 6.875 m²

B = 2.7 m (for square footing) L = 2.7 m

$$A_{\text{prov}} = 7.29 \text{ m}^2$$

$$\text{Step-3 : Upward pressure (q)} = w/A_{\text{pro}} = \frac{500 \times 1.5}{7.29} = 102.88 < \text{spc.}$$

Step-4 : Bending moment calculation

$$M_{\text{uxx}} = M_{\text{uyy}}$$

$$M_{\text{uxx}} = q \times B \times \left(\frac{B-b}{8} \right) = 103 \times 2.78 \times \frac{(2.7-0.35)^2}{8} = 191.97 \text{ kN/m}$$

Step – 5 : Depth calculation

$$M_{\text{u max}} = 0.30 f_{\text{ck}} \frac{x_{\text{u max}}}{d} \left[1.092 \frac{x_{\text{u max}}}{d} \right] \times bd^2$$

$$\Rightarrow 191.27 \times 10^6 = 0.36 \times 20 \times 0.48 \left[1 - 0.42 \times 0.48 \right] \times 2700d^2$$

$$\Rightarrow d = \sqrt{25910} = 160 \text{ mm} \square 350$$

Step -6 : Steel calculation

$$(A_{\text{st}})_x = (A_{\text{st}})_y$$

$$\frac{M_u}{bd^2} = \frac{191.97 \times 10^6}{2700 \times 350^2} = 0.58$$

$$P_t = 0.412$$

$$(A_{\text{st}})_{\text{min}} = 3.605 \text{ mm}^2$$

$$(A_{\text{st}})_{\text{min}} = \frac{0.12}{100} \times 2700 \times 400 = 1236 \text{ mm}^2$$

$$A_{\text{st}} > A_{\text{st min}}$$

Step-7 : Check for one way shear critical section 'd' from the face of the column

$$Z_v \leq k$$

$$Z_v = v_u / bd$$

$$\begin{aligned} v_u &= q \times L \left(\frac{L-1}{2} - d \right) \\ &= 103 \times 2.7 \left(\frac{2.7-0.35}{2} - 0.35 \right) \\ &= 229.43 \text{ kN} \end{aligned}$$

$$Z_v = \frac{229.43 \times 10^3}{2700 \times 350} = 0.24 \text{ N/mm}^2$$

$$k = 1, P_t = 0.412, Q_c = 0.44 \text{ N/mm}^2, k_c = 0.44 \text{ N/m}^2$$

$$Z_v < k_c \text{ (it is satisfy)}$$

Step – 8 : Check for the two way shear

Critical section $d/2$ from the face of the column

$$Z_v \leq k_s z_i$$

$$K_s = 0.5 + \beta_c$$

$$m\beta_c = b/L = 0.35/0.35 = 1$$

$$K_s = 0.5 + 1 = 1.5 \approx 1$$

$$I_c = 0.25 \sqrt{f_{ck}} = 0.25 \times \sqrt{20} = 10118 \text{ N/mm}^2$$

$$K_{ic} = 1 \times 1.118 = 1.118 \text{ N/mm}^2$$

$$Z_v = V_u/bd$$

$$L^1 = L + d = 0.35 + 0.35 = 0.7 \text{ m}$$

$$B^1 = 0.7 \text{ m}$$

$$b = 2(b^1 + c^1) = 2(0.7 + 0.7) = 2.8 \text{ m}$$

$$d^1 = 0.35 \text{ m}$$

$$V = q \times [(L \times B) - (L^1 \times b^1)]$$

$$= 103 \times [(2.7 \times 2.7) - (0.7 \times 0.7)]$$

$$= 700 \text{ kN}$$

$$Z_v = \frac{700 \times 10^3}{2700 \times 350} = 0.74 \text{ N/m}^2$$

$$Z_v < K Z_c$$

Step – 9 : Check for load transfer

Nominal bearing stress < Allowable bearing stress

So, nominal bearing stress = (column load)/(Area of column)

$$A_1 = L \times B$$

$$L = 1 + 4D = 350 + (4 \times 400) = 1950 \text{ mm}$$

$$A_1 = 1950 \times 1950 = 3802500 \text{ mm}^2$$

$$A_2 = 350 \times 350 = 122500 \text{ mm}^2$$

$$\sqrt{\frac{A_1}{A_2}} = 5.57 < 2$$

so it is taken as 2

$$\text{Allowable bearing stress} = 0.45 f_{ck} = \sqrt{\frac{A_1}{A_2}} = 0.45 \times 20 \times 2 = 18 \text{ N/mm}^2$$

$$\text{Column load} = 1.5 \times 750 = 1125 \text{ kN}$$

$$\frac{\text{Column load}}{\text{area}} = \frac{1125 \times 10^3}{350 \times 350} = 9.18 < 18$$

It is safety

∴ size of the footing = 2.7×2.7 m

Depth of footing = 400 mm